

VIRGINIA STANDARDS OF LEARNING

Released Test

GRADE 8

MATHEMATICS

2009 Mathematics Standards of Learning

Released Spring 2014

Property of the Virginia Department of Education

Copyright ©2014 by the Commonwealth of Virginia, Department of Education, P.O. Box 2120, Richmond, Virginia 23218-2120. All rights reserved. Except as permitted by law, this material may not be reproduced or used in any form or by any means, electronic or mechanical, including photocopying or recording, or by any information storage or retrieval system, without written permission from the copyright owner. Commonwealth of Virginia public school educators may reproduce any portion of these released tests for non-commercial educational purposes without requesting permission. All others should direct their written requests to the Virginia Department of Education, Division of Student Assessment and School Improvement, at the above address or by e-mail to Student_Assessment@doe.virginia.gov.

SAMPLE A

Three views of a rectangular prism are shown.



Front



Right Side



Top

Which could be this prism?

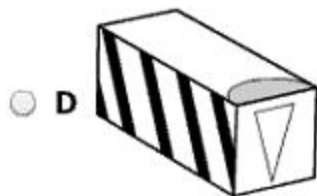
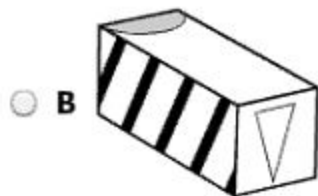
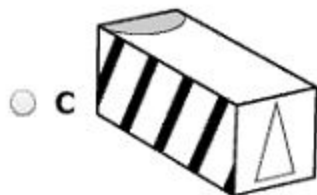
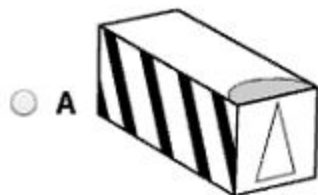

Directions: Type your answer in the box. Your answer must be in the form of an improper fraction. Use "/" for the fraction bar.

SAMPLE B

What is one solution to $5x + 1 = 7$?

Your answer must be in the form of an improper fraction.

$x =$

What is the value of $4(6 + 2)^2$?

- A 64
- B 160
- C 256
- D 1,024

Directions: Type your answer in the box.

What is $-\sqrt{324}$?

If $x = 2$ and $t = 4$, what is the value of $\frac{1}{8}(x^3 - 4)(t^2 + 8)$?

- A 12
- B 4
- C -72
- D -144

A food company reduced the amount of salt in one of their food products from 700 milligrams to 630 milligrams. What is the percent decrease in the amount of salt in this food product?

- A** 10%
- B** 12%
- C** 70%
- D** 90%

Which number is an irrational number?

- A 5.499
- B $\sqrt{17}$
- C $-\sqrt{9}$
- D -10

Directions: Click on a box to choose each number you want to select. You must select all correct numbers.

Identify each number between 1.7×10^0 and 195%.

1.8×10^1	$1\frac{7}{8}$	18.5	$\frac{7}{4}$
-------------------	----------------	------	---------------

Dora bought a total of 48 cupcakes. Each cupcake cost \$0.55, including tax. Of the cupcakes she bought, $\frac{3}{8}$ were vanilla cupcakes. What was the total cost of only the vanilla cupcakes?

- A \$26.40
- B \$16.50
- C \$9.90
- D \$6.60

Which list of numbers is ordered from greatest to least ?

- A 52%, 0.45, 3.1×10^1 , $\frac{10}{11}$
- B 3.1×10^1 , 52%, 0.45, $\frac{10}{11}$
- C 52%, 3.1×10^1 , $\frac{10}{11}$, 0.45
- D 3.1×10^1 , $\frac{10}{11}$, 52%, 0.45

Emil bought a camera for \$268.26, including tax. He made a down payment of \$12.00 and paid the balance in 6 equal monthly payments. What was Emil's monthly payment for this camera?

- A** \$42.71
- B** \$44.71
- C** \$46.71
- D** \$56.71

Which pair of numbers are both between 6 and 7 ?

- A $\sqrt{30}$ and $\sqrt{42}$
- B $\sqrt{36}$ and $\sqrt{49}$
- C $\sqrt{37}$ and $\sqrt{50}$
- D $\sqrt{42}$ and $\sqrt{48}$

Directions: Type your answer in the box.

Kyle caught 9 insects for his science project in the first week. He caught 13 insects in the second week. What is the percent increase in the number of insects Kyle caught from the first week to the second week? Round your answer to the nearest whole number.

%

Which number in this list is NOT an integer?

$$\frac{12}{4}, -4^2, \sqrt{25}, -4.8$$

- A $\frac{12}{4}$
- B -4^2
- C $\sqrt{25}$
- D -4.8

Which statement best describes $\sqrt{50}$?

- A Exactly 7
- B Exactly 25
- C Between 7 and 8
- D Between 24 and 26

What is the value of $\frac{8}{3}n^3$ when $n = \frac{3}{2}$?

- A 4
- B 6
- C 9
- D 12

For the rectangle shown, which equation can be used to find the value of x ?

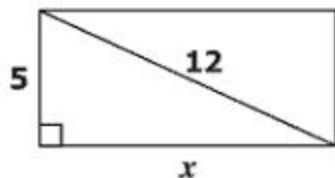

- A $(x + 5)^2 = 12^2$
- B $5^2 + x^2 = 12^2$
- C $5^2 + 12^2 = x^2$
- D $5 + 12 = x^2$

What is the area of this polygon?

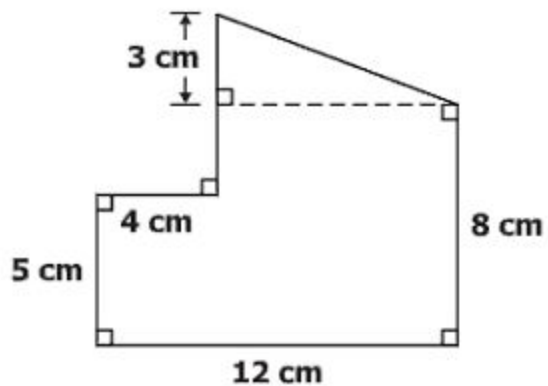

- A 77 sq cm
- B 86 sq cm
- C 96 sq cm
- D 108 sq cm

Which grid shows only a translation of the shaded polygon to create the unshaded polygon?

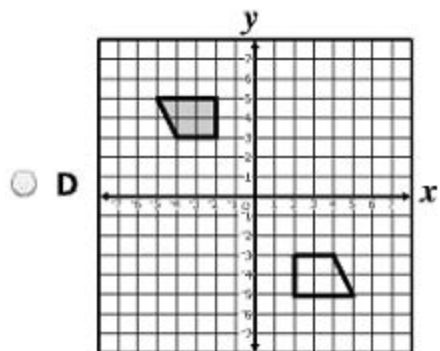
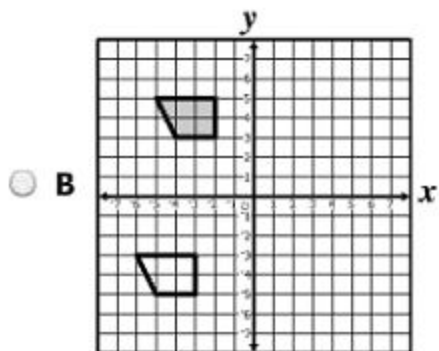
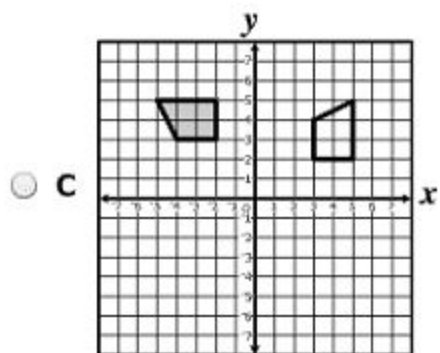
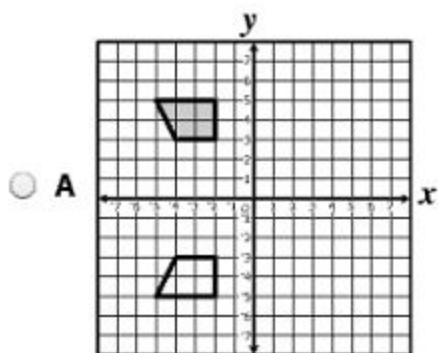

Which of the following could be the measurements of two supplementary angles?

- A 7° and 83°
- B 83° and 83°
- C 97° and 83°
- D 117° and 83°

Directions: Click on the grid to plot each point you want to select. A line segment will connect the points you select.

Dwight drew a line segment on a coordinate grid. He plans to reflect the line segment over the y -axis.

Graph the new line segment by selecting the endpoints of the segment.

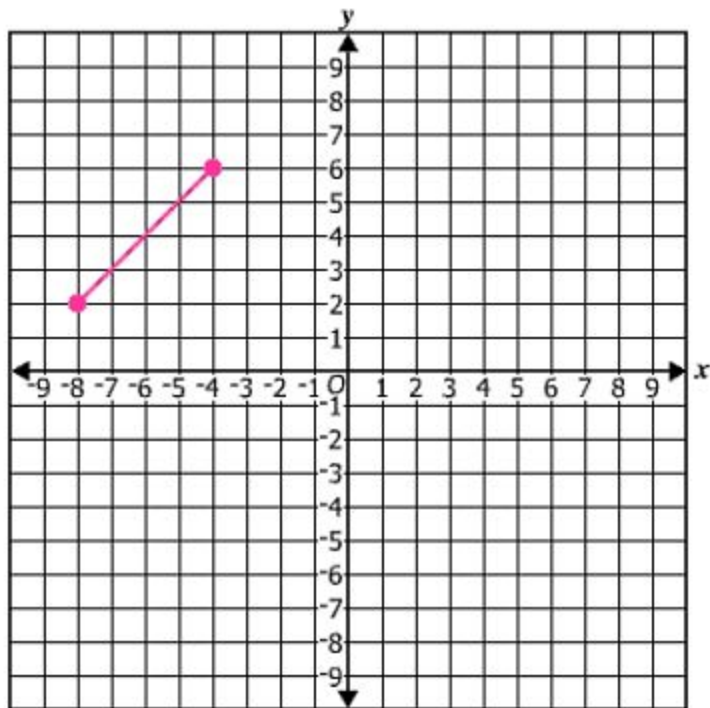

Josh has two rectangular prisms. The length of the second prism is 10 times the length of the first prism. The heights and widths of the two prisms are the same. Which best describes the volume of the second prism?

- A** The volume is 10 times the volume of the first prism.
- B** The volume is 30 times the volume of the first prism.
- C** The volume is 100 times the volume of the first prism.
- D** The volume is 1,000 times the volume of the first prism.

This figure is formed by a square and an isosceles trapezoid.

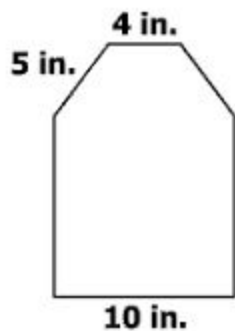

What is the perimeter of this figure?

- A 19 in.
- B 34 in.
- C 39 in.
- D 44 in.

The radius of the base of a cone is 6 inches. The height of the cone is 6 inches. Which is closest to the volume of the cone?

- A 75 cu in.
- B 113 cu in.
- C 226 cu in.
- D 678 cu in.

One piece of a stained glass is transformed three times.

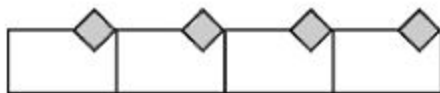

What transformation was used to create this section of the stained glass window?

- A Translation
- B Reflection
- C Rotation
- D Dilation

A three-dimensional figure is constructed using identical cubes. Three views of this figure are shown.

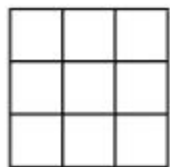

Front

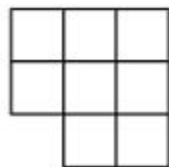

Top

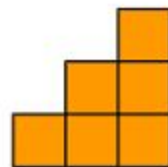

Right Side

Which could be this three-dimensional figure?

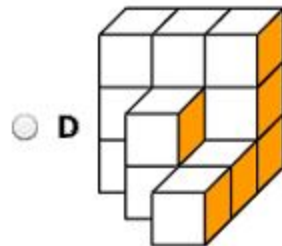
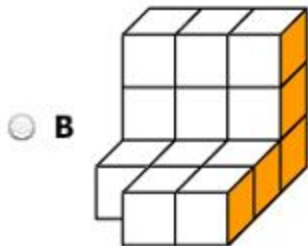
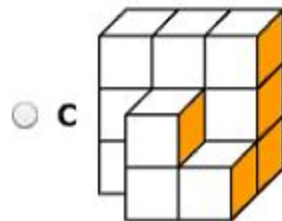

A wire connects the top of a flagpole to the ground as shown.

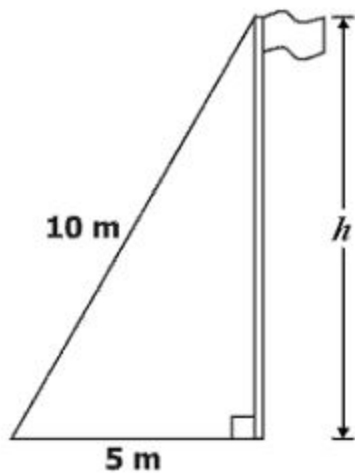

Which is closest to the height, h , of the flagpole?

- A 3.2 m
- B 5.0 m
- C 8.7 m
- D 11.2 m

Raymond needs to cover the entire surface of this square-based pyramid with paper.

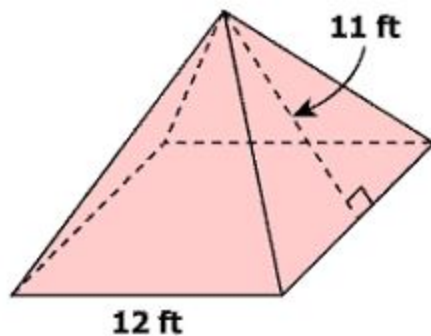

What is the minimum amount of paper he will need?

- A 276 sq ft
- B 408 sq ft
- C 528 sq ft
- D 672 sq ft

Directions: Click on a box to choose each angle you want to select. You must select all correct angles.

Look at the angles.

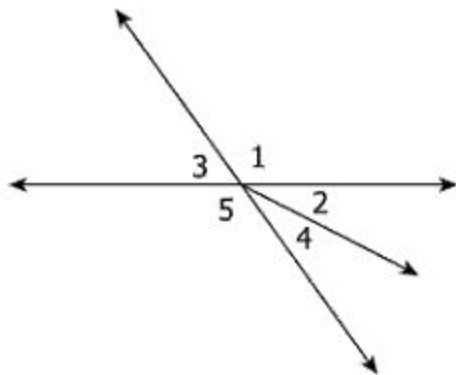

Identify each angle that is adjacent to Angle 2.

Angle 1

Angle 3

Angle 4

Angle 5

Directions: Click on all the correct answers.

Identify each three-dimensional figure that could be represented by these three views.

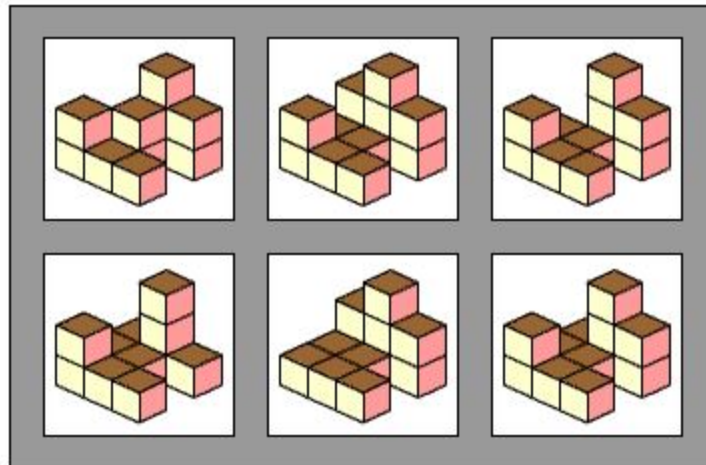

What is the solution of this equation?

$$x = 5x + 6$$

- A $-\frac{3}{2}$
- B -1
- C 1
- D $\frac{3}{2}$

Which line appears to contain both ordered pairs shown in this table?

x	y
2	0
0	-4

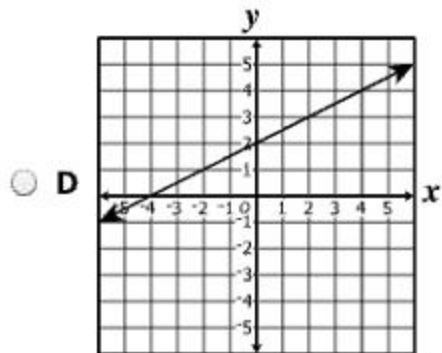
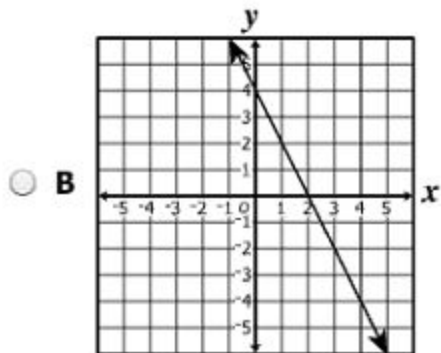
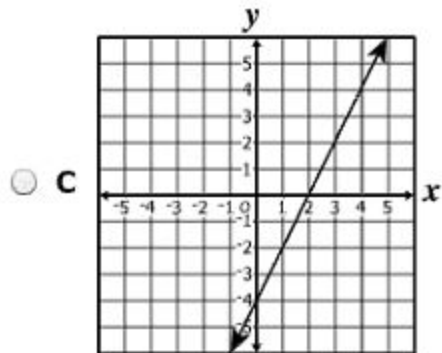
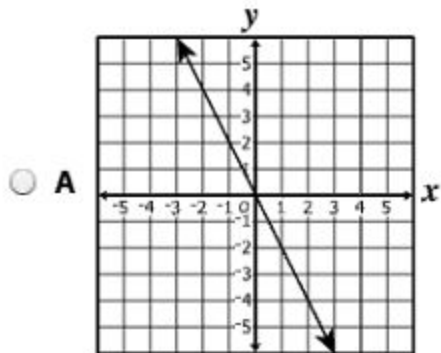

Directions: Click on a box to choose each equation you want to select. You must select all correct equations.

Identify each equation that illustrates the commutative property of multiplication.

$$xy + 3 = yx + 3$$

$$6(x + 7) = 6x + 42$$

$$3x + (5x + 7x) = (3x + 5x) + 7x$$

$$4(3) = 3(4)$$

$$12 + (-3) = (-3) + 12$$

The hourly wages of the 25 employees at a restaurant are shown.



Based on the graph, what is the mean hourly wage of the 25 employees at this restaurant?

- A \$11.75
- B \$9.36
- C \$9.00
- D \$8.56

What value of x makes this equation true?

$$5x + 8 + 3x = 26 + 6x$$

- A 36
- B 17
- C 16
- D 9

Which line appears to be a graph of the equation shown?

$$y = -2x - 1$$

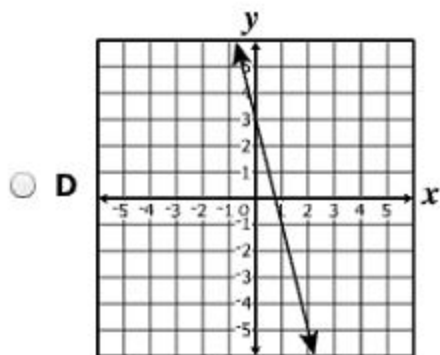
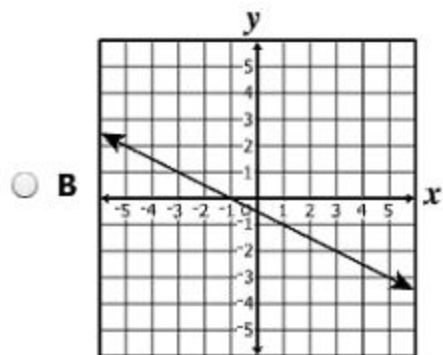
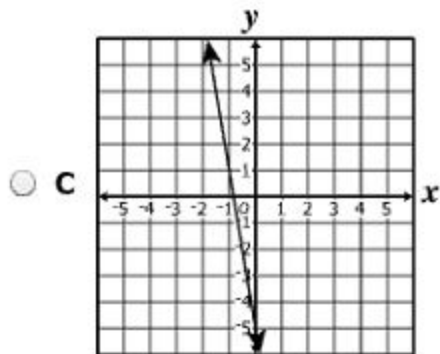
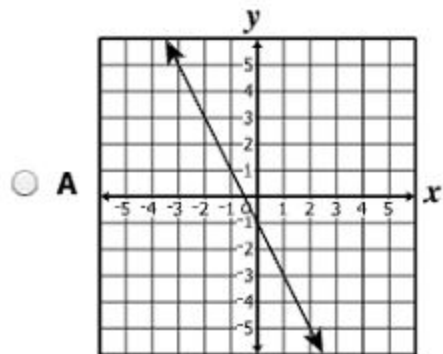

Two fair coins are flipped at the same time. What is the probability that both display tails?

- A $\frac{1}{8}$
- B $\frac{1}{4}$
- C $\frac{1}{3}$
- D $\frac{1}{2}$

Which graph appears to contain all the ordered pairs in this relation?

x	y
-2	-1
1	2
4	3

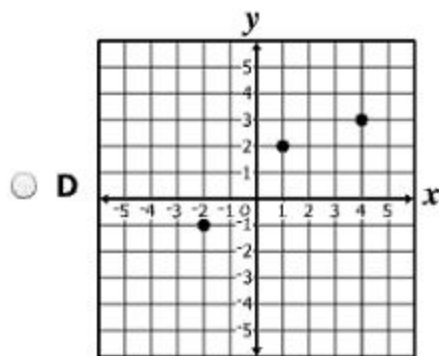
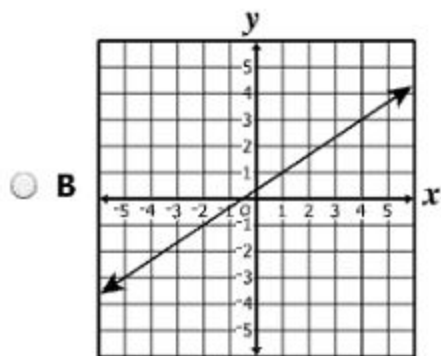
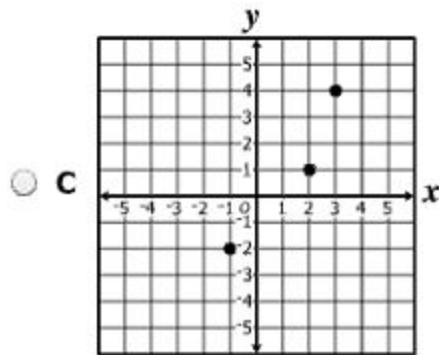
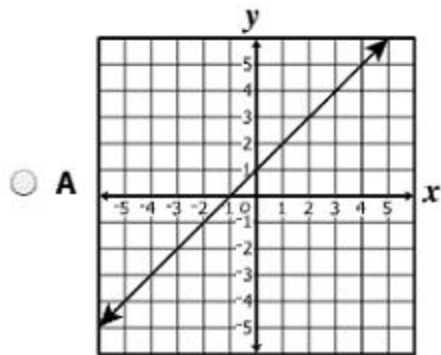

Which graph best represents the solution to $\frac{7}{8} \geq \frac{1}{4}x + \frac{1}{2}$?

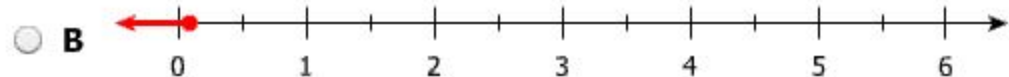
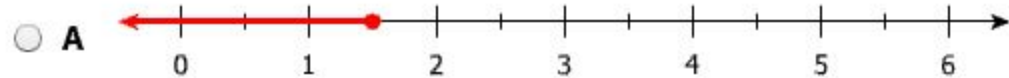

Which of these best describes the relationship of the data shown on this scatterplot?

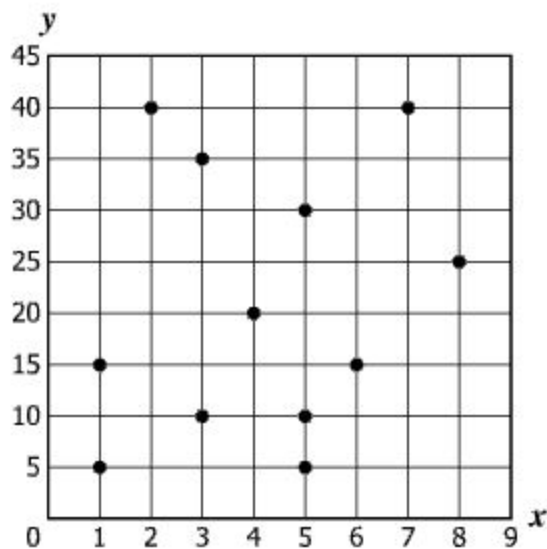

- A Constant relationship
- B Negative relationship
- C Positive relationship
- D No relationship

What is the solution to $\frac{n+4}{2} - 3 = 13$?

- A $n = 4$
- B $n = 14$
- C $n = 16$
- D $n = 28$

The graph shows Anna's height on each of her last five birthdays.

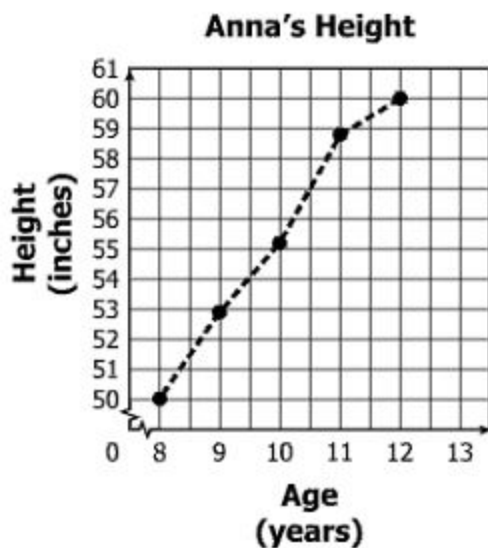

Based on the graph, between which two consecutive years was the increase in Anna's height the greatest?

- A Between 8 and 9 years
- B Between 9 and 10 years
- C Between 10 and 11 years
- D Between 11 and 12 years

Which best represents $y = x - 1$?

A

x	y
0	1
1	0

B

x	y
3	2
6	4

C

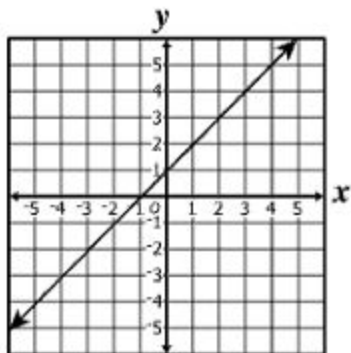

D

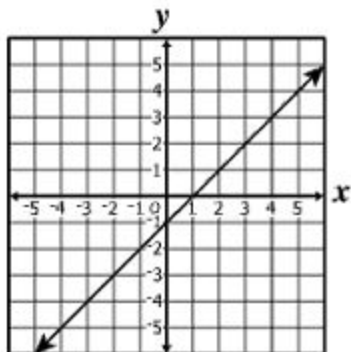

What is the range of this relation?

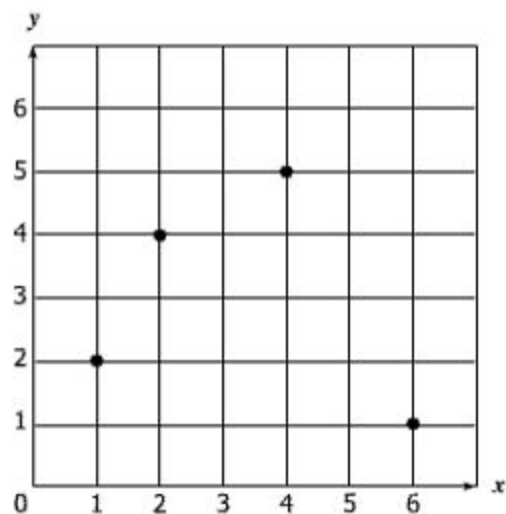

- A {1, 2, 4, 6}
- B {1, 2, 4, 5}
- C {1, 2, 4, 5, 6}
- D {0, 1, 2, 3, 4, 5, 6}

What is the solution of this inequality?

$$1.6 \geq 0.8x + 4$$

- A $-3 \geq x$
- B $-3 \leq x$
- C $7 \geq x$
- D $7 \leq x$

Which is the greatest value in the range of $y = -5x + 3$ for the domain $\{-2, 0, 1, 3\}$?

- A 3
- B 8
- C 13
- D 18

Which table contains only points that lie on the line represented by $y = \frac{2}{3}x - 6$?

A

x	y
0	-6
9	6

C

x	y
-3	-8
6	-2

B

x	y
0	6
12	2

D

x	y
-3	-4
3	-2

The graph shows the number of text messages two students sent each day for 4 days.

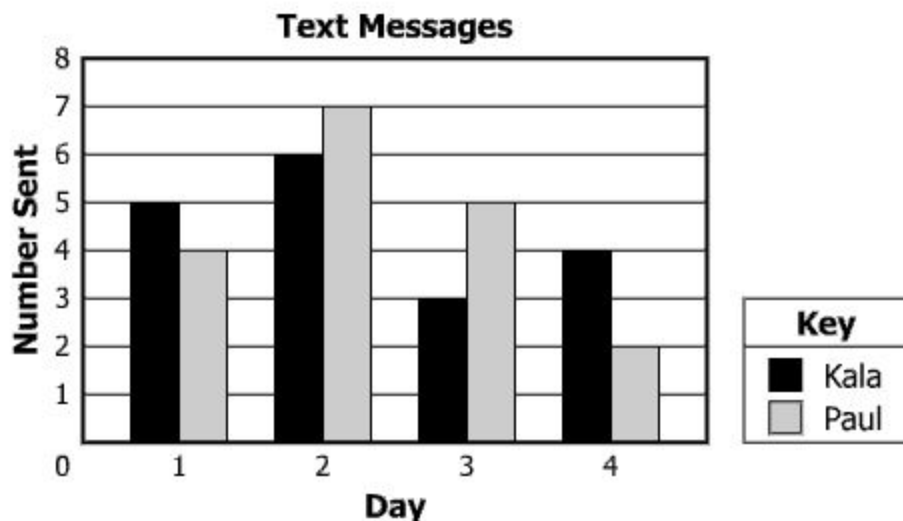

Based on the graph, which statement is true?

- A** On Day 2 and Day 3, the total number of text messages sent by Paul was 4 more than the total number of text messages sent by Kala.
- B** The total number of text messages sent by Kala was the same as the total number sent by Paul for these four days.
- C** The mean number of text messages Kala sent on Day 2 and Day 4 was exactly 4.5.
- D** Kala sent fewer text messages than Paul on Day 3 and Day 4 combined.

The scatterplot shows the relationship between Marvin's age and the time it took him to run a mile.

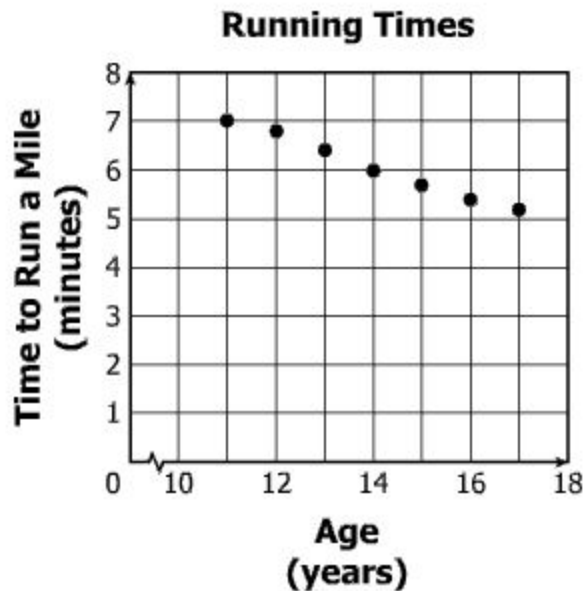

Which statement best describes the relationship between Marvin's age and the time it takes him to run a mile?

- A As Marvin's age increased, the time it took him to run a mile increased.
- B As Marvin's age increased, the time it took him to run a mile decreased.
- C As Marvin's age increased, the time it took him to run a mile remains constant.
- D There is no relationship between Marvin's age and the time it took him to run a mile.

Which relation has a domain of $\{3, 5, 8\}$?

- A $\{(5, 1), (3, 4), (8, 2), (3, 3)\}$
- B $\{(3, 2), (5, 1), (8, 3), (1, 4)\}$
- C $\{(2, 8), (1, 3), (3, 5)\}$
- D $\{(3, 8), (5, 3), (3, 5)\}$

Directions: Click on the grid to plot each ordered pair.

A table of ordered pairs is shown.

x	y
-2	2
4	-1
8	-3

Graph the relation represented by the table of ordered pairs.

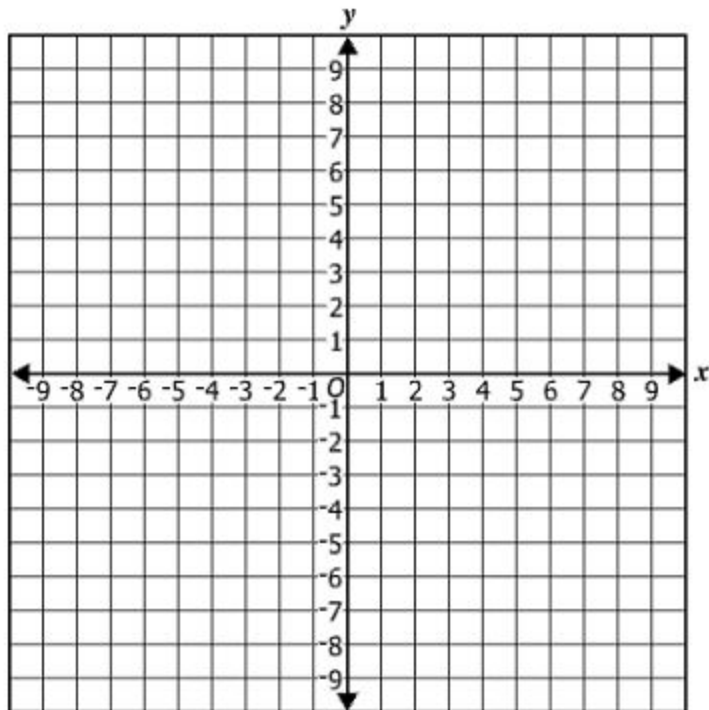

A box contains 9 new light bulbs and 6 used light bulbs. Each light bulb is the same size and shape. Meredith will randomly select 2 light bulbs from the box without replacement. What is the probability Meredith will select a new light bulb and then a used light bulb?

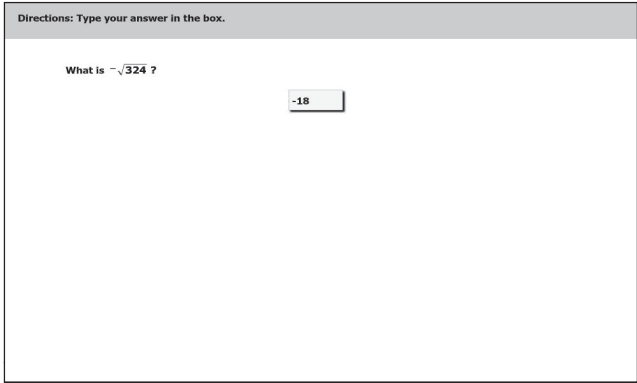

- A $\frac{1}{54}$
- B $\frac{2}{15}$
- C $\frac{6}{25}$
- D $\frac{9}{35}$

**Grade 8 Mathematics
Released Test Spring 2014
Answer Key**

Sequence Number	Item Type: Multiple Choice (MC) or Technology-Enhanced Item (TEI)	Correct Answer	Reporting Category	Reporting Category Description
1	MC	C	001	Number, Number Sense, Computation and Estimation
2	TEI	Typed Response: -18 (and all equivalent answers) 	001	Number, Number Sense, Computation and Estimation
3	MC	A	001	Number, Number Sense, Computation and Estimation
4	MC	A	001	Number, Number Sense, Computation and Estimation
5	MC	B	001	Number, Number Sense, Computation and Estimation

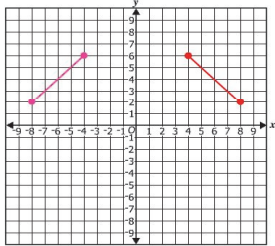
Sequence Number	Item Type: Multiple Choice (MC) or Technology-Enhanced Item (TEI)	Correct Answer	Reporting Category	Reporting Category Description
6	TEI	<p>$1\frac{7}{8}$ (the second box from the left) and $\frac{7}{4}$ (the last box on the right)</p> <p>Both of these answers, and only these answers, must be selected.</p> <div data-bbox="491 472 1173 881" style="border: 1px solid black; padding: 5px;"> <p>Directions: Click on a box to choose each number you want to select. You must select all correct numbers.</p> <p>Identify each number between 1.7×10^0 and 195%.</p> <div style="text-align: center;"> <div style="display: flex; justify-content: space-around; align-items: center;"> <div style="border: 1px solid gray; padding: 2px;">1.8×10^0</div> <div style="border: 1px solid gray; padding: 2px;">$1\frac{7}{8}$</div> <div style="border: 1px solid gray; padding: 2px;">18.5</div> <div style="border: 1px solid gray; padding: 2px;">$\frac{7}{4}$</div> </div> </div> </div>	001	Number, Number Sense, Computation and Estimation
7	MC	C	001	Number, Number Sense, Computation and Estimation
8	MC	D	001	Number, Number Sense, Computation and Estimation
9	MC	A	001	Number, Number Sense, Computation and Estimation
10	MC	D	001	Number, Number Sense, Computation and Estimation
11	TEI	<p>Typed Response: 44</p> <div data-bbox="491 1053 1178 1463" style="border: 1px solid black; padding: 5px;"> <p>Directions: Type your answer in the box.</p> <p>Kyle caught 9 insects for his science project in the first week. He caught 13 insects in the second week. What is the percent increase in the number of insects Kyle caught from the first week to the second week? Round your answer to the nearest whole number.</p> <div style="text-align: center;"> <input style="width: 40px; text-align: center;" type="text" value="44"/> % </div> </div>	001	Number, Number Sense, Computation and Estimation

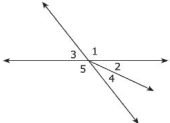
Sequence Number	Item Type: Multiple Choice (MC) or Technology-Enhanced Item (TEI)	Correct Answer	Reporting Category	Reporting Category Description
12	MC	D	001	Number, Number Sense, Computation and Estimation
13	MC	C	001	Number, Number Sense, Computation and Estimation
14	MC	C	001	Number, Number Sense, Computation and Estimation
15	MC	B	002	Measurement and Geometry
16	MC	C	002	Measurement and Geometry
17	MC	B	002	Measurement and Geometry
18	MC	C	002	Measurement and Geometry
19	TEI	Points must be plotted on the coordinate plane at (4,6) and (8,2). A line segment will connect the points.	002	Measurement and Geometry
		<p>Directions: Click on the grid to plot each point you want to select. A line segment will connect the points you select.</p> <p>Dwight drew a line segment on a coordinate grid. He plans to reflect the line segment over the y-axis.</p> <p>Graph the new line segment by selecting the endpoints of the segment.</p> 		
20	MC	A	002	Measurement and Geometry
21	MC	D	002	Measurement and Geometry
22	MC	C	002	Measurement and Geometry
23	MC	A	002	Measurement and Geometry
24	MC	A	002	Measurement and Geometry
25	MC	C	002	Measurement and Geometry
26	MC	B	002	Measurement and Geometry

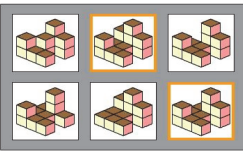
Sequence Number	Item Type: Multiple Choice (MC) or Technology-Enhanced Item (TEI)	Correct Answer	Reporting Category	Reporting Category Description
27	TEI	<p>Angle 1 (the first box from the left) and Angle 4 (the third box from the left)</p> <p>Both answers, and only these answers, must be selected.</p> <p>Directions: Click on a box to choose each angle you want to select. You must select all correct angles.</p> <p>Look at the angles.</p>  <p>Identify each angle that is adjacent to Angle 2.</p> <p>Angle 1 Angle 3 Angle 4 Angle 5</p>	002	Measurement and Geometry
28	TEI	<p>The figure located in the first row, second column; and the figure located in the second row, third column.</p> <p>Both figures, and only these figures, must be selected.</p> <p>Directions: Click on all the correct answers.</p> <p>Identify each three-dimensional figure that could be represented by these three views.</p>  	002	Measurement and Geometry
29	MC	A	003	Probability, Statistics, Patterns, Functions, and Algebra

Sequence Number	Item Type: Multiple Choice (MC) or Technology-Enhanced Item (TEI)	Correct Answer	Reporting Category	Reporting Category Description					
30	MC	C	003	Probability, Statistics, Patterns, Functions, and Algebra					
31	TEI	$xy + 3 = yx + 3$ (the first box from the top) and $4(3) = 3(4)$ (the fourth box from the top) Both of these answers, and only these answers, must be selected. <div style="border: 1px solid gray; padding: 5px; margin-top: 10px;"> <p style="font-size: small; margin: 0;">Directions: Click on a box to choose each equation you want to select. You must select all correct equations.</p> <p style="text-align: center; margin: 5px 0;">Identify each equation that illustrates the commutative property of multiplication.</p> <table style="margin: auto; border-collapse: collapse;"> <tr><td style="border: 1px solid gray; padding: 2px;">$xy + 3 = yx + 3$</td></tr> <tr><td style="border: 1px solid gray; padding: 2px;">$6(x + 7) = 6x + 42$</td></tr> <tr><td style="border: 1px solid gray; padding: 2px;">$3x + (5x + 7x) = (3x + 5x) + 7x$</td></tr> <tr><td style="border: 1px solid gray; padding: 2px;">$4(3) = 3(4)$</td></tr> <tr><td style="border: 1px solid gray; padding: 2px;">$12 + (-3) = (-3) + 12$</td></tr> </table> </div>	$xy + 3 = yx + 3$	$6(x + 7) = 6x + 42$	$3x + (5x + 7x) = (3x + 5x) + 7x$	$4(3) = 3(4)$	$12 + (-3) = (-3) + 12$	003	Probability, Statistics, Patterns, Functions, and Algebra
$xy + 3 = yx + 3$									
$6(x + 7) = 6x + 42$									
$3x + (5x + 7x) = (3x + 5x) + 7x$									
$4(3) = 3(4)$									
$12 + (-3) = (-3) + 12$									
32	MC	B	003	Probability, Statistics, Patterns, Functions, and Algebra					
33	MC	D	003	Probability, Statistics, Patterns, Functions, and Algebra					
34	MC	A	003	Probability, Statistics, Patterns, Functions, and Algebra					
35	MC	B	003	Probability, Statistics, Patterns, Functions, and Algebra					
36	MC	D	003	Probability, Statistics, Patterns, Functions, and Algebra					
37	MC	A	003	Probability, Statistics, Patterns, Functions, and Algebra					
38	MC	D	003	Probability, Statistics, Patterns, Functions, and Algebra					
39	MC	D	003	Probability, Statistics, Patterns, Functions, and Algebra					
40	MC	C	003	Probability, Statistics, Patterns, Functions, and Algebra					
41	MC	D	003	Probability, Statistics, Patterns, Functions, and Algebra					
42	MC	B	003	Probability, Statistics, Patterns, Functions, and Algebra					
43	MC	A	003	Probability, Statistics, Patterns, Functions, and Algebra					
44	MC	C	003	Probability, Statistics, Patterns, Functions, and Algebra					
45	MC	C	003	Probability, Statistics, Patterns, Functions, and Algebra					
46	MC	B	003	Probability, Statistics, Patterns, Functions, and Algebra					
47	MC	B	003	Probability, Statistics, Patterns, Functions, and Algebra					

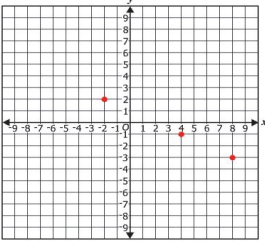
Sequence Number	Item Type: Multiple Choice (MC) or Technology-Enhanced Item (TEI)	Correct Answer	Reporting Category	Reporting Category Description								
48	MC	A	003	Probability, Statistics, Patterns, Functions, and Algebra								
49	TEI	<p>Three points must be plotted on the coordinate plane at $(-2, 2)$, $(4, -1)$, and $(8, -3)$.</p> <p>Directions: Click on the grid to plot each ordered pair.</p> <p>A table of ordered pairs is shown.</p> <table border="1" data-bbox="621 558 701 630"> <thead> <tr> <th>x</th> <th>y</th> </tr> </thead> <tbody> <tr> <td>-2</td> <td>2</td> </tr> <tr> <td>4</td> <td>-1</td> </tr> <tr> <td>8</td> <td>-3</td> </tr> </tbody> </table> <p>Graph the relation represented by the table of ordered pairs.</p> 	x	y	-2	2	4	-1	8	-3	003	Probability, Statistics, Patterns, Functions, and Algebra
x	y											
-2	2											
4	-1											
8	-3											
50	MC	D	003	Probability, Statistics, Patterns, Functions, and Algebra								

Spring 2014 Released
Grade 8 Mathematics Standards of Learning Test
Total Raw Score to Scaled Score Conversion Table

Total Raw Score If you get this many items correct:	Total Scaled Score Then your converted scaled score is:
0	0
1	194
2	225
3	244
4	258
5	269
6	278
7	286
8	294
9	300
10	307
11	312
12	318
13	323
14	328
15	333
16	337
17	342
18	346
19	351
20	355
21	359
22	363
23	367
24	371
25	375
26	379
27	384
28	388
29	392
30	396
31	400
32	405
33	409
34	414
35	418
36	423
37	428
38	434
39	439
40	445
41	451
42	458
43	466
44	475
45	484
46	496
47	510
48	530
49	562
50	600

A **total raw score** (left column) is converted to a **total scaled score** (right column). The total scaled score may range from 0 to 600.

A scaled score of 400 or more means the student passed the SOL test, while a scaled score of 399 or less means the student did not pass the test. A scaled score of 500 or more indicates the student passed the SOL test at an advanced level.

