

VIRGINIA STANDARDS OF LEARNING

Spring 2012 Released Test

UNITED STATES HISTORY TO 1865

Form H0112, CORE 1

Property of the Virginia Department of Education

Copyright ©2012 by the Commonwealth of Virginia, Department of Education, P.O. Box 2120, Richmond, Virginia 23218-2120. All rights reserved. Except as permitted by law, this material may not be reproduced or used in any form or by any means, electronic or mechanical, including photocopying or recording, or by any information storage or retrieval system, without written permission from the copyright owner. Commonwealth of Virginia public school educators may reproduce any portion of these released tests for non-commercial educational purposes without requesting permission. All others should direct their written requests to the Virginia Department of Education, Division of Student Assessment and School Improvement, at the above address or by e-mail to Student_Assessment@doe.virginia.gov.

Directions

Read each question and choose the best answer. Then fill in the circle on your answer document for the answer you have chosen.

Sample

In the mid-1800s, a gold rush led many people to move to —

- A** Texas
- B** Kansas
- C** California
- D** Louisiana

1 One subject of conflict between settlers and American Indians was the —

- A** exchange of food
- B** ownership of land
- C** style of farming techniques
- D** number of trading posts

2

IN THE NAME OF GOD, AMEN. We . . . the Loyal Subjects of . . .
King James, by the Grace of God . . . Having undertaken for the
Glory of God, and Advancement of the Christian Faith, a Voyage . . .

— Mayflower Compact

This document was most likely written by the colonists of —

- F** Georgia
- G** Roanoke Island
- H** North Carolina
- J** Plymouth

3 The recovery and analysis of evidence from the past are most important in the study of —

- A** psychology
- B** sociology
- C** archaeology
- D** biology

4

Navigational Tool

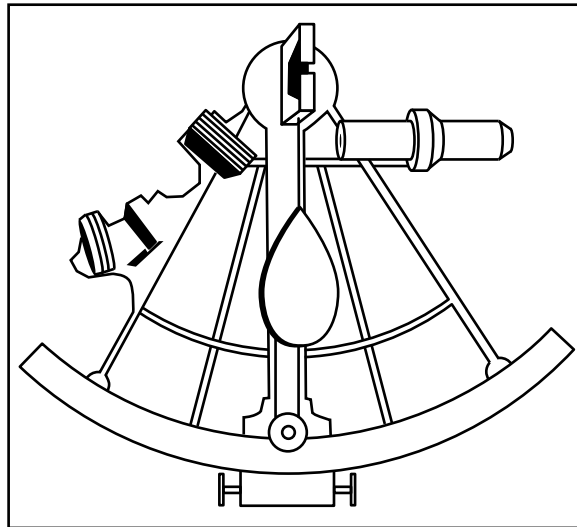

Tools such as this one were used to —

- F** improve military weapons
- G** aid African agriculture
- H** find natural resources
- J** aid European exploration

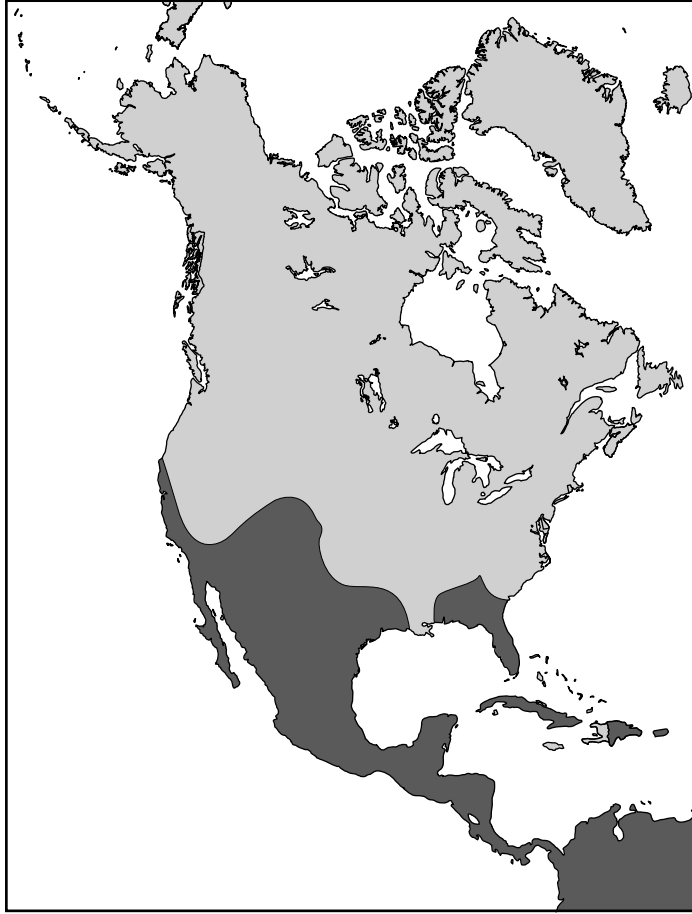
North America

What was one reason that Europeans explored the darker-shaded area?

- A** To learn new languages
- B** To avoid political persecution
- C** To spread religion
- D** To cure diseases

6 Which kind of work did most women do in colonial America?

- F** Sold furniture and clothes
- G** Cared for people and houses
- H** Taught in schools and colleges
- J** Served in hospitals and nurseries

7 Which colonial goods were usually exchanged for manufactured goods from England?

- A** Gold
- B** Slave labor
- C** Crafts
- D** Raw materials

8 How did the Proclamation of 1763 affect the British colonists?

- F** It limited the western movement of settlers.
- G** It led to an increase in fur trading.
- H** It prevented trade with American Indians.
- J** It led to the French and Indian War.

Individual	Role During the American Revolution
_____? _____	Commander of the Continental Army

Which name replaces the question mark?

- A** Patrick Henry
- B** George Washington
- C** Lord Cornwallis
- D** Benjamin Franklin

10 Which individual helped gain French support for American independence?

- F** Benjamin Franklin
- G** Thomas Jefferson
- H** Patrick Henry
- J** Paul Revere

11 The colonists won the Revolutionary War because they —

- A** had a more powerful navy
- B** fought on their own territory
- C** had better weapons
- D** had more supplies

12 At the Constitutional Convention, the Great Compromise settled a debate about —

- F** judicial powers
- G** the presidential elections
- H** state representation
- J** the amendment process

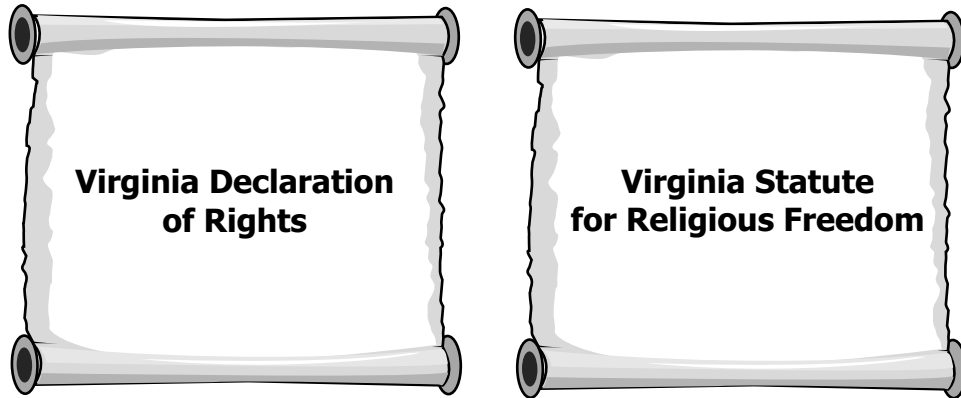

These documents were the basis for the —

- A** Declaration of Independence
- B** Mayflower Compact
- C** Articles of Confederation
- D** Bill of Rights

14 The War of 1812 helped the United States gain the respect of —

- F** European countries
- G** Mexico
- H** African nations
- J** Canada

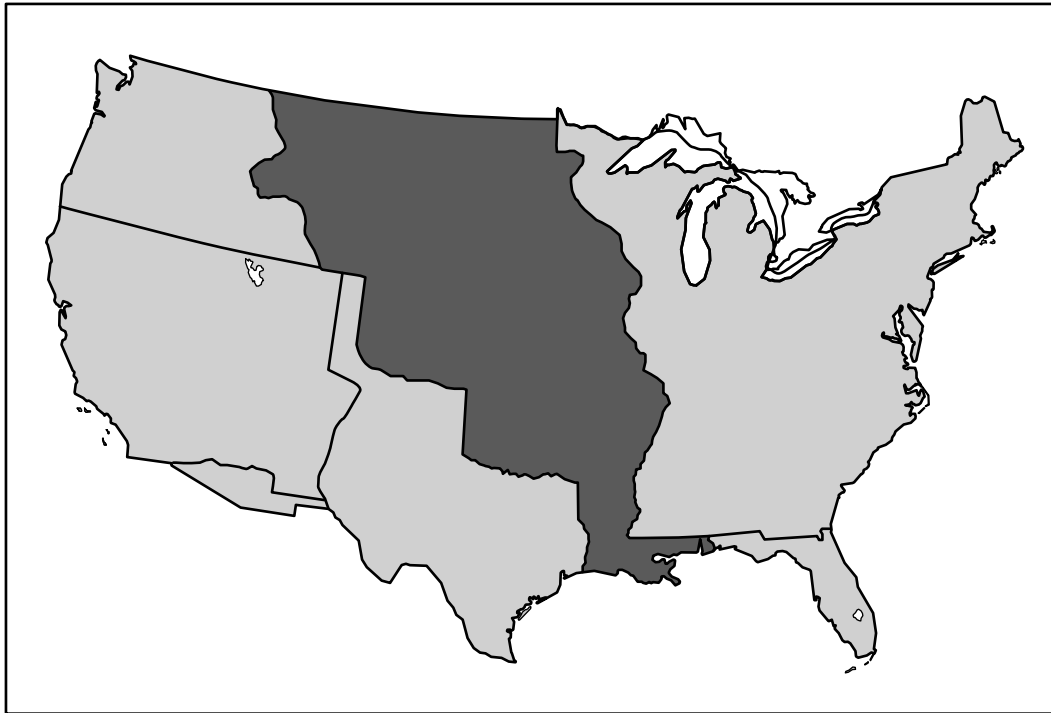
Territorial Expansion, 1801–1861

The darker-shaded area on this map was sold to the United States by —

- A** Mexico
- B** Spain
- C** France
- D** Canada

We hold these truths to be self-evident: That all men are created equal . . .

— Declaration of Independence, 1776

We hold these truths to be self-evident; that all men and women are created equal . . .

— Declaration of Sentiments and Resolutions, 1848

This quote from 1848 uses language from the Declaration of Independence to —

- F** protest against changing the Constitution of the United States
- G** show that American philosophies continue to support equal rights
- H** protest the reasons given for Revolutionary War actions
- J** show that European nations want to increase equal rights

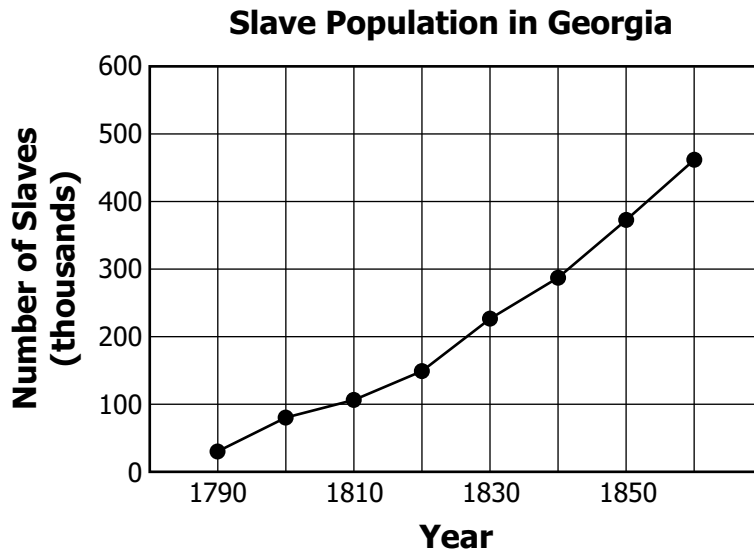

Which invention contributed most to the change shown in this graph?

- A** Steamboat
- B** Reaper
- C** Cotton gin
- D** Steel plow

18 One major difference between the North and the South that helped lead to the Civil War was —

- F** disagreements over tariffs
- G** conflict over treaties
- H** disagreements about resources
- J** competition for factories

19 The Missouri Compromise tried to satisfy people with different beliefs about slavery by —

- A** admitting one free state and one slave state to the Union
- B** prohibiting slavery in the Kansas Territory
- C** ending the slave trade throughout the country
- D** spreading slavery to plantations growing cotton and tobacco

20

. . . that government of the people, by the people,
for the people shall not perish from the Earth.

— Abraham Lincoln

President Lincoln is explaining that the main purpose of the Civil War was to —

- F** punish Southern states
- G** save the Union
- H** grant women's suffrage
- J** settle western territories

FREEDOM,

Protection, Pay, and a Call to Military Duty!

On the 1st day of January, 1863, the President of the United States proclaimed FREEDOM to over THREE MILLIONS OF SLAVES. This decree [order] is to be enforced by all the power of the Nation.

The purpose of this poster was to recruit men for the —

- A** Union Army
- B** Confederate Navy
- C** Reconstruction Congress
- D** Red Cross

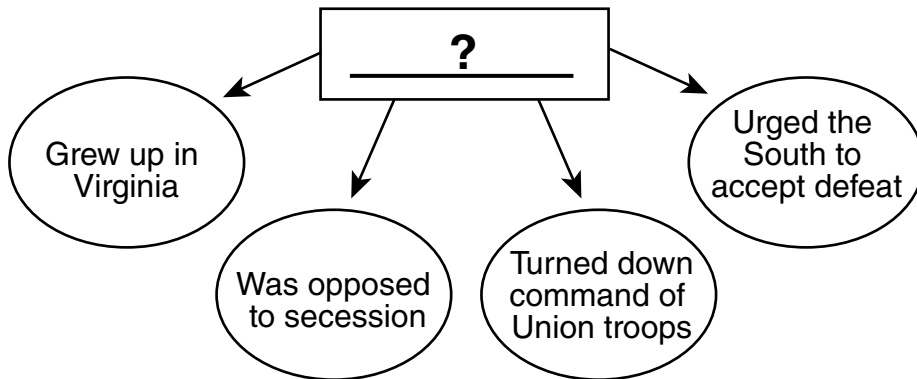

What Civil War figure is described in the diagram?

- F** Thomas "Stonewall" Jackson
- G** Jefferson Davis
- H** Robert E. Lee
- J** Frederick Douglass

23 The leading cause of death during the Civil War resulted from —

- A** battle wounds
- B** cannon shells
- C** starvation
- D** disease

24 Which statement is true of women during the 1850s?

- F** Most women had college educations.
- G** Women were given voting rights.
- H** Most women held limited property rights.
- J** Women were given equal business opportunities.

25 Which ocean is located directly north of Europe?

- A** Pacific
- B** Atlantic
- C** Indian
- D** Arctic

26 Which continent is part of a larger landmass?

- F** Asia
- G** Africa
- H** Australia
- J** Antarctica

27 Why was the Battle of Gettysburg a turning point of the Civil War?

- A** It gave the North control of the Mississippi River.
- B** It allowed the South to capture the Union capital.
- C** The South was able to surround the Union Army.
- D** The North stopped a Confederate invasion.

28 Which geographic features are most associated with the Coastal Plain?

- F** Lakes and high plateaus
- G** Rolling flatlands with many rivers
- H** Broad lowlands with many harbors
- J** Mountain ranges and valleys

North America

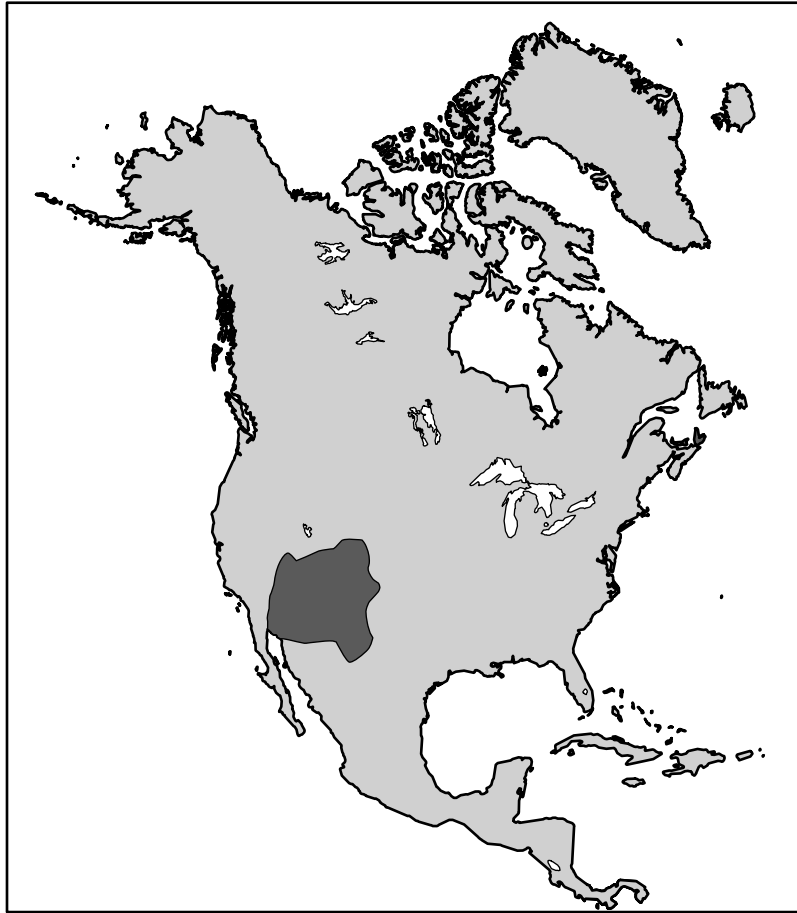

Which American Indian group lived in the darker-shaded area on this map?

- A Iroquois
- B Pueblo
- C Kwakiutl
- D Inuit

30 Most major cities and towns in the United States during the 18th century were located near —

- F** waterways
- G** central areas of the country
- H** mountains
- J** warm areas of the country

31 Which body of water forms part of the United States boundary with Mexico?

- A** Rio Grande
- B** Atlantic Ocean
- C** Colorado River
- D** Columbia River

United States, 1863

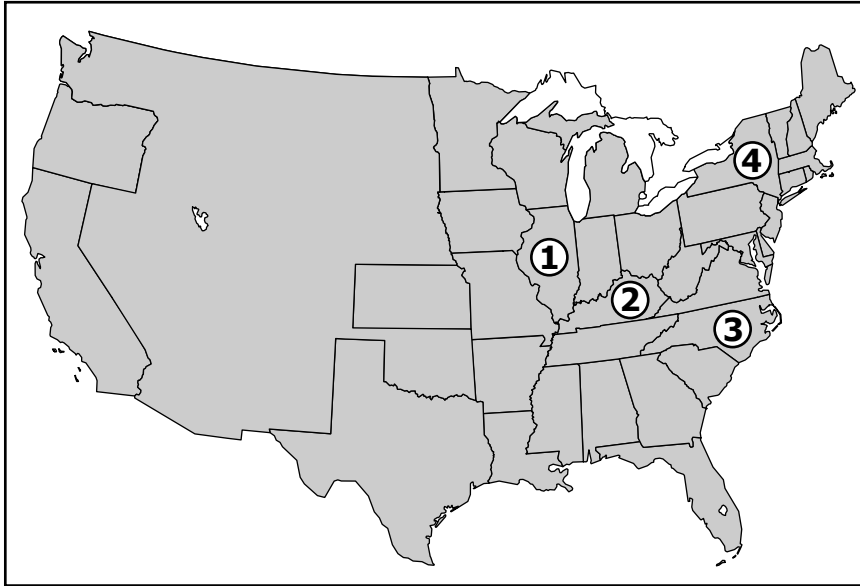

Which state was known as a border state during the Civil War?

- F 1
- G 2
- H 3
- J 4

33 Which action was part of the Union plan during the Civil War?

- A Supporting the Underground Railroad
- B Blocking Southern ports
- C Securing territory in the Rocky Mountains
- D Ending a partnership with Canada

Buffalo is to Lakota
As
? is to Inuit

Which of these best completes this comparison?

- F** Corn
- G** Seal
- H** Cattle
- J** Squash

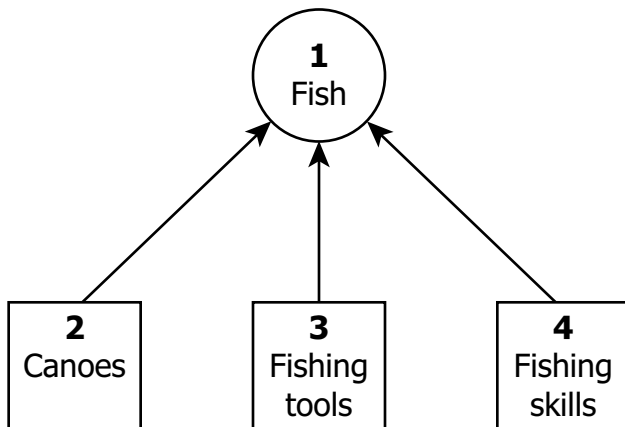
**American Indian
Food Production**

Which number in this diagram represents a human resource?

- A** 1
- B** 2
- C** 3
- D** 4

36 Which would most likely be found in the Mid-Atlantic colonies?

- F** Plantation farming
- G** Shipbuilding industries
- H** Market towns
- J** Gold mining

Africa

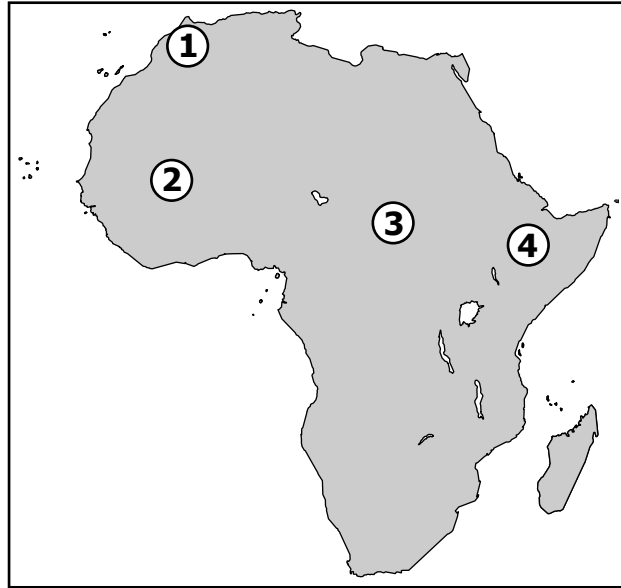

Which number on this map shows the location of Ghana?

- A 1
- B 2
- C 3
- D 4

**Weaknesses of the
Articles of Confederation**

- No executive branch
- No judicial branch
- No power to tax by Congress
- _____?

Which phrase best completes this list?

- F** No common currency
- G** No national legislature
- H** No political parties
- J** No states' rights

39 According to the Declaration of Independence, government receives its power from the —

- A** judiciary
- B** legislature
- C** military
- D** people

40 Manifest Destiny was the belief that the United States should —

- F** expand for the good of the country
- G** create a national court system
- H** become independent from Great Britain
- J** increase immigration from Europe



Answer Key-3176-H0112

Test Sequence Number	Correct Answer	Reporting Category	Reporting Category Description
1	B	001	Pre-Columbian Times to the 1770s
2	J	001	Pre-Columbian Times to the 1770s
3	C	001	Pre-Columbian Times to the 1770s
4	J	001	Pre-Columbian Times to the 1770s
5	C	001	Pre-Columbian Times to the 1770s
6	G	001	Pre-Columbian Times to the 1770s
7	D	001	Pre-Columbian Times to the 1770s
8	F	002	Revolution and the New Nation
9	B	002	Revolution and the New Nation
10	F	002	Revolution and the New Nation
11	B	002	Revolution and the New Nation
12	H	002	Revolution and the New Nation
13	D	002	Revolution and the New Nation
14	F	002	Revolution and the New Nation
15	C	003	Expansion, Reform, and the Civil War
16	G	003	Expansion, Reform, and the Civil War
17	C	003	Expansion, Reform, and the Civil War
18	F	003	Expansion, Reform, and the Civil War
19	A	003	Expansion, Reform, and the Civil War
20	G	003	Expansion, Reform, and the Civil War
21	A	003	Expansion, Reform, and the Civil War
22	H	003	Expansion, Reform, and the Civil War
23	D	003	Expansion, Reform, and the Civil War
24	H	003	Expansion, Reform, and the Civil War
25	D	004	Geography
26	F	004	Geography
27	D	004	Geography
28	H	004	Geography
29	B	004	Geography
30	F	004	Geography
31	A	004	Geography
32	G	004	Geography
33	B	004	Geography
34	G	005	Civics and Economics
35	D	005	Civics and Economics
36	H	005	Civics and Economics
37	B	005	Civics and Economics
38	F	005	Civics and Economics
39	D	005	Civics and Economics
40	F	005	Civics and Economics

Spring 2012 Released
US History I Standards of Learning History Test
Total Raw Score to Scaled Score Conversion Table for
Multiple Choice Form H0112, Core 1

Total Raw Score If you get this many items correct:	Total Scaled Score Then your converted scaled score is:
0	0
1	149
2	192
3	218
4	238
5	253
6	267
7	278
8	289
9	298
10	307
11	315
12	323
13	331
14	338
15	345
16	352
17	359
18	365
19	372
20	378
21	385
22	392
23	398
24	405
25	412
26	419
27	426
28	433
29	441
30	449
31	458
32	468
33	478
34	490
35	503
36	518
37	537
38	564
39	600
40	600

A **total raw score** (left column) is converted to a **total scaled score** (right column). The total scaled score may range from 0 to 600.

A scaled score of 400 or more means the student passed the SOL test, while a scaled score of 399 or less means the student did not pass the test. A scaled score of 500 or more indicates the student passed the SOL test at an advanced level.